



APPLICATION OF SWT AND MISO METHODS FOR MEASUREMENT AND ANALYSIS OF ELECTRO- ACOUSTIC AND AUDIO SYSTEMS

Frantisek Kadlec, Karel Ulovec

*Faculty of Electrical Engineering, Czech Technical University in Prague, Technicka 2,
166 27 Prague, Czech Republic, e-mail: kadlec@fel.cvut.cz*

Antonin Novak

Laboratoire d'Acoustique de l'Universite du Maine, UMR CNRS 6613, Le Mans, France

This contribution deals with performance evaluation of electro-acoustic and audio systems with non-linearities by a combination of two existing methods: *Sweep Sine Wave Signal Technique (SWT)* and *Multiple Input Single Output (MISO)* nonlinear modeling. The signal, driving a system under test, is a logarithmically swept sine wave. Transfer functions of the system under test may be obtained from the response of the system and the swept sine wave "inverse filter" response. These transfer functions are further processed. Then the system under test can be considered as a *MISO* nonlinear model, consisting of a parallel combination of nonlinear branches, containing filters and memory-less power-law distortion functions. Such a model facilitates determination of a nonlinear response to the input signal. This method has been successfully used for analysis of various components of electro-acoustic and audio systems. In the first application described in our contribution, this method was used for a detailed analysis of transfer functions of a complete electro-acoustic system including an artificial head. This system is used for the analysis of spatial perception as well as determination of a signal compression impact on its perception. In the other application, this test method was used for measurement and evaluation of the whole transmission chain, from studio all the way to the listener. The signal source was a studio recorded *CD* that was transmitted by *FM* radio to the listener's receiver, where it was demodulated, monitored and analyzed. A good correlation with traditional methods of measurement was found.

1. Introduction

Currently, there is a lot of new development in the field of digital signal processing (*DSP*) in multimedia technology. The application of new methods of *DSP* in studio and telecommunications then brings the requirement of using corresponding methods of performance measurement and analysis of transfer properties of these electro-acoustic systems. We also cannot neglect application of these methods for testing experimental equipment used to obtain the parameters of spatial perception of acoustic signals. One such example can be the usage of an artificial head not only from its original purpose, but also for modeling of the acoustic signal transfer by bone transduction. In general, we deal with determination of transfer functions of these acoustic and electro-acoustic systems, specifically finding their impulse and frequency responses and non-linear distortion in various modes of operation.

In the equipment for multimedia technology we usually do not find significant levels of non-linear distortion at normal levels. However, during system overdriving some distortion may take place. Then, we are mainly trying to find the causes of distortion and methods for its minimizing or elimination. The electro-acoustic systems contain, aside from classic components such as microphones, amplifiers and loudspeakers, also some additional components with specific properties. Those are, for instance, systems for signal compression, limiters etc. As for the signal compression, from the perception point of view, here we are talking about the testing of equipment performance proper, rather than analysis of its perception.

Historically, the first method that was partially able to perform measurement and analysis of electro-acoustic systems, was developed still in analogue age: *Time Delay Spectrometry*. Today the *MLSSA* method is probably the most used one for this purpose. It uses a pseudorandom binary signal to drive the electro-acoustic system under test. This method is very robust, tolerant of external noise ingress influence on measurement accuracy. It cannot, however, be used for determination or even estimate of non-linear distortion of systems. Currently, the *Sweep Sine Wave Signal Technique (SWT)* method appears to be the most suitable. It uses a logarithmically swept harmonic signal to drive the system under test. We used the *SWT* method in conjunction with a *Multiple Input Single Output (MISO) nonlinear modeling* consisting of a parallel combination of nonlinear branches, containing filters and memory-less power-law distortion functions.

2. Description of Measuring Methods

Since the above mentioned *SWT* and *MISO* methods have been adequately published from the theoretical point of view [1, 2, 3], we limit ourselves here to a principal description, necessary for the explanation of their use for practical measurement.

2.1 Sweep Sine Signal Measurement Technique

The measurement and analysis is based on the use of logarithmically swept harmonic signal for driving the system under test. Driving log-sweep signals can be written [1]

$$x(t) = \sin \left\{ \frac{2\pi f_1 T}{\ln \frac{f_2}{f_1}} \left[\left(\frac{f_2}{f_1} \right)^{\frac{t}{T}} - 1 \right] \right\}, \quad 0 \leq t < T \quad (1)$$

For determination of the impulse response $h(t)$ of a system under test a so-called inverse filter $f(t)$ is defined for the next calculation as

$$[x(t) w(t)] \otimes f_i(t) = \delta(t) \quad (2)$$

Where a time window $w(t)$ eliminates transient behavior at the beginning and end of the test signal $x(t)$. Using the relation between input driving signal $x(t)$ and the signal at the device output $y(t)$ we can obtain the resulting formula for calculation of the impulse response (IR)

$$h(t) = f_i(t) \otimes y(t) . \quad (3)$$

The impulse response of the tested system $h(t)$ may be obtained as a convolution of the inversion filter $f_i(t)$ with the response $y(t)$ of a system under test. If the system under test produces non-linear distortion, we can describe it as a non-linear memory less system. Such a system can be described by N^{th} order Volterra kernels [4].

By calculation we obtain the total IR of the system under test, consisting of several partial IR , corresponding to individual distorting components. By proper selection of driving signal parameters, i.e. its duration, we can achieve the separation of these partial responses. The total IR can then be expressed as

$$h(t) = \sum_{n=1}^N h_n(t) . \quad (4)$$

By Fourier transformations $FT\{h_n(t)\}$ we obtain the partial frequency spectra $H_n(f)$

$$H_n(f) = \int_{t_n - \Delta t}^{t_n + \Delta t} h_n(t) e^{-j2\pi f t} dt . \quad (5)$$

2.2 Multiple Input Single Output Measurement Technique

A nonlinear *MISO* model with several parallel branches depicted in Fig. 1, or more exactly its particular case with power series expansion, corresponding to a polynomial Hammerstein model, seems to be an optimal compromise between the simplicity of the model and its accuracy. The classical nonlinear *MISO* method [5] for nonlinear systems identification is based either on the estimation of *power* and *cross spectral densities (PSD, CSD)* of inputs and outputs of the model, in the case of mutually correlated inputs, or just only on the estimation of the *CSD* between output and inputs if the inputs are decorrelated. In the latter case, the inputs decorrelation is generally based on the estimation of the *CSD* between these inputs.

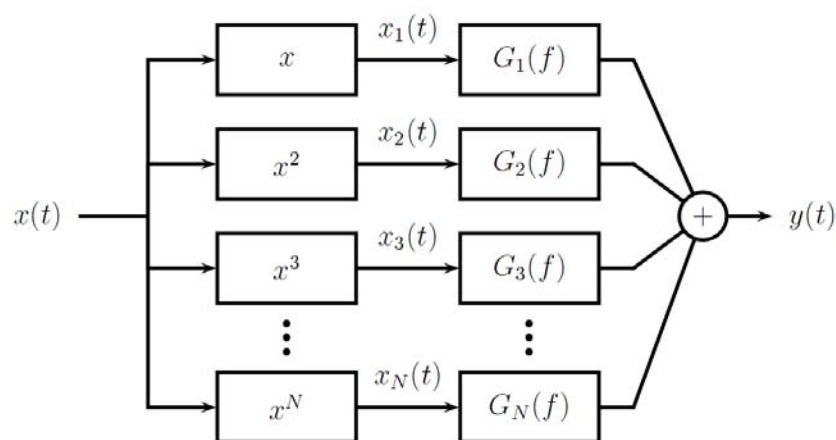

Figure 1. Nonlinear *MISO* model with power series equivalent to the generalized Hammerstein model.

In this paper, we keep the idea of using the *MISO* model, but we use the *SWT* method instead of methods based on *PSD* and *CSD* in order to estimate the filters $G_n(f)$ of the nonlinear model. The relation between the higher order transfer responses $H_n(f)$ described in previous section and the filters $G_n(f)$ is detailed in [6]. The experimental measurement consists of two steps:

- (a) analysis of the nonlinear system under test using the *SWT* method,
- (b) estimation of filters $G_n(f)$ of the nonlinear model.

For the first step, the swept sine signal $x(t)$ is generated and brought to the input of the signal. Next, the output signal is recorder as $y(t)$. The nonlinear convolution between the output $y(t)$ and the inverse filter $f_i(t)$ is applied to get the higher order transfer responses $H_n(f)$. The second step is transformation between the higher order transfer responses $H_n(f)$ and the filters $G_n(f)$.

3. Measurement and Analysis of Electro-acoustic and Audio Systems

For actual measurement and analysis of systems we use a combined *SWT-MISO* method. In this contribution we describe its application on experiments with an artificial head used to determine transfer responses from the perception of acoustic signals point of view.

We also advanced our previous testing of the whole communication chain. We experimented with both the frequency modulated signal and the digital transfer. The result of this analysis can show us the status of signal transmission from the master control output through compression and other signal processing towards the transmitter, the transmission itself and subsequent reception, including reproduction by an electro-acoustic system. For measurement and analysis of electro-acoustic and audio systems with non-linearities we designed and are still further developing a program using *MATLAB*® software. Driving signals can be generated either by a PC's external sound card or can be played back from a disk. The measured responses are recorded and preprocessed. This process involves evaluation of measured responses, elimination of erroneous responses, averaging of time domain responses, etc. Evaluation is performed by *ADOBE AUDITION*® software and subsequently analyzed by *SWT-MISO* method.

3.1 Measurement and Analysis of Transfer Functions of Artificial Head

For determination of transfer properties of transducers, such as headsets, and for investigation of spatial perception of sound we use the artificial head (*AH*). Currently, the *AH* is designed in such a way, that it enables also a modeling of bone transduction. We show two examples of measurement on *AH*. The system block diagram is shown in Fig. 2. In the first example we show the application of *SWT-MISO* method for determination of transfer response of system, consisting of ear enclosing headphones, sitting on *AH*, having a 1/2" measuring microphone inside the ear channel. The second application was the determination of signal behavior within the *AH*, when one ear receives the signal from a driven headphone, while the other ear, covered by an inactive headphone, receives only the signal conducted by the head material itself. The tests were performed in a semi-anechoic chamber. We used a sweeping signal $100\text{ Hz} - 8\text{ kHz}$ with a period of $T = 20\text{ sec}$. and a sampling frequency $f_s = 96\text{ kHz}$.

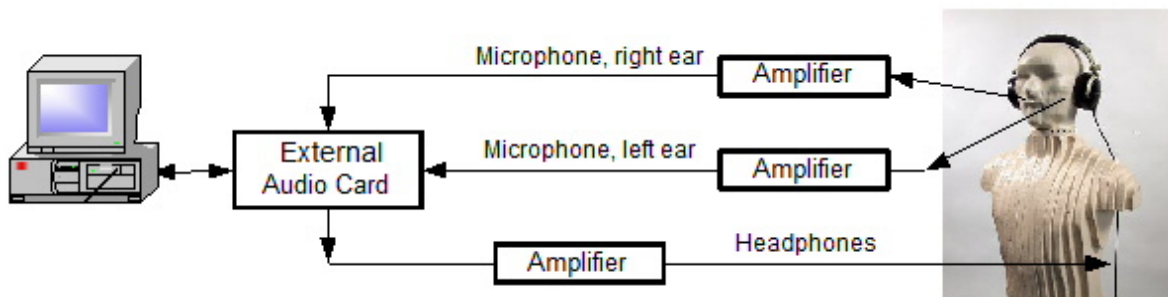

Figure 2. Block diagram of measurements of transfer functions of the artificial head with headphones.

3.1.1 Headphone to eardrum transfer response

Fig. 3a shows the time response $y(t)$ of artificial head with headphones. The measured impulse response $h(t)$, which can be divided into several following partial components $h_n(t)$, is shown in Fig. 3b. The impulse response $h(t)$ is shown as an absolute value $|h(t)|$ in dB scale, for a better graphic resolution. By application of a Fourier transformation $FT\{h_n(t)\}$ we obtain the frequency spectra $H_n(f)$ that are depicted in Fig. 4.

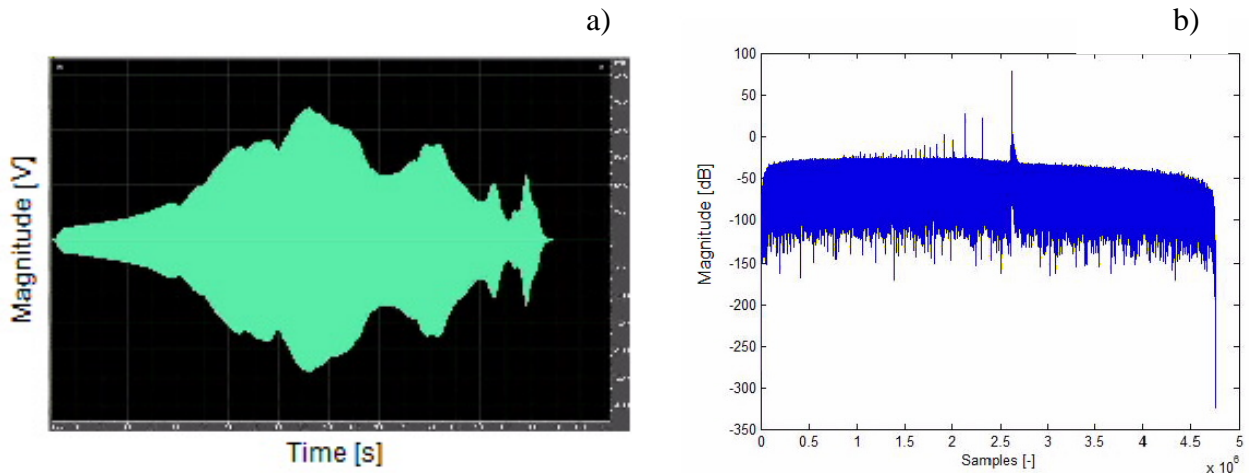

Figure 3. a) Time response $y(t)$ of artificial head with headphones to a swept driving signal;
b) Partial components $h_n(t)$ of the impulse response $h(t)$.

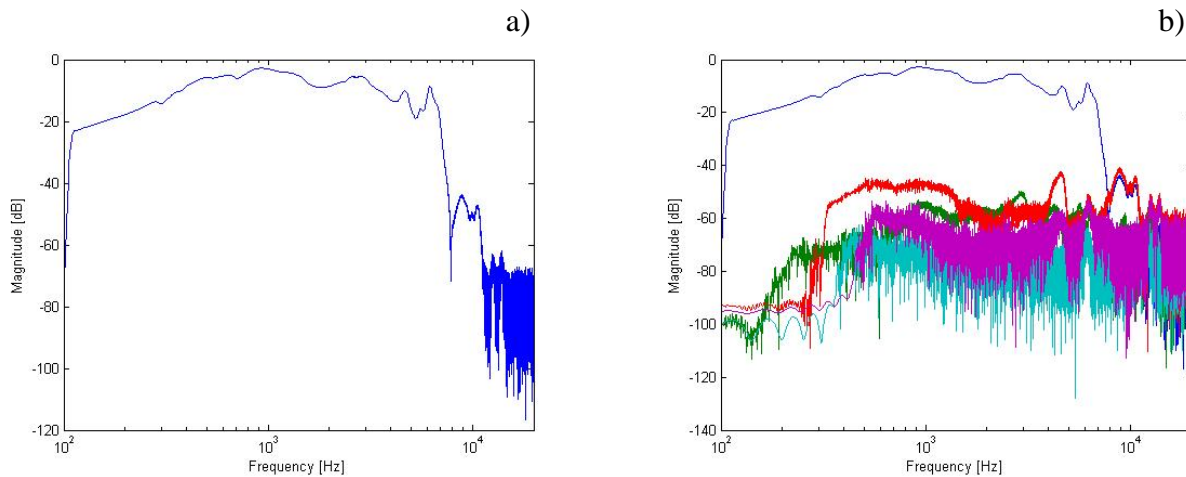

Figure 4. a) Modulus of the transfer function $H_1(f)$ of the artificial head with headphones;
b) Modulus of the transfer function $H_1(f)$ together with higher non-linear components $H_n(f)$.

3.1.2 Signal ingress within the artificial head, due to assumed bone conduction

This experiment deals with the possibility of acoustic signal perception by means of bone conduction model. The test setup and test signal are identical to the previous test. Due to the reduced detected signal level, additional 30 dB gain was used.

Analysis of the results enables us to obtain knowledge about transfer properties of AH , both as a whole and individual results, concerning the system drivers, impact of external ear on acoustic signal transfer, crosstalk etc. Results are shown in Fig. 5 and Fig. 6.

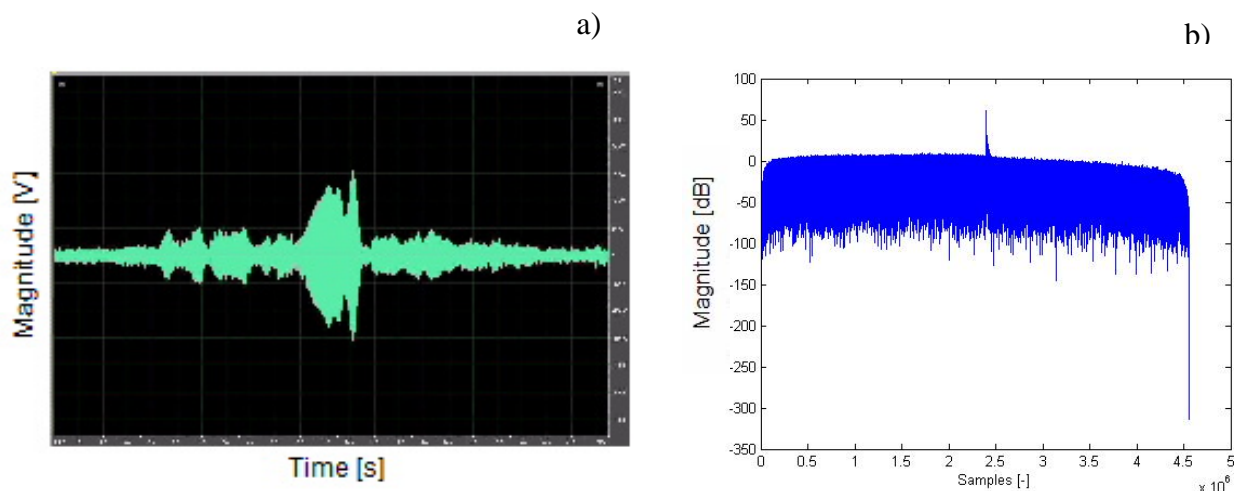

Figure 5. Signal crosstalk within the artificial head; a) Time response to the swept driving signal; b) Impulse response $h(t)$ of the crosstalk signal.

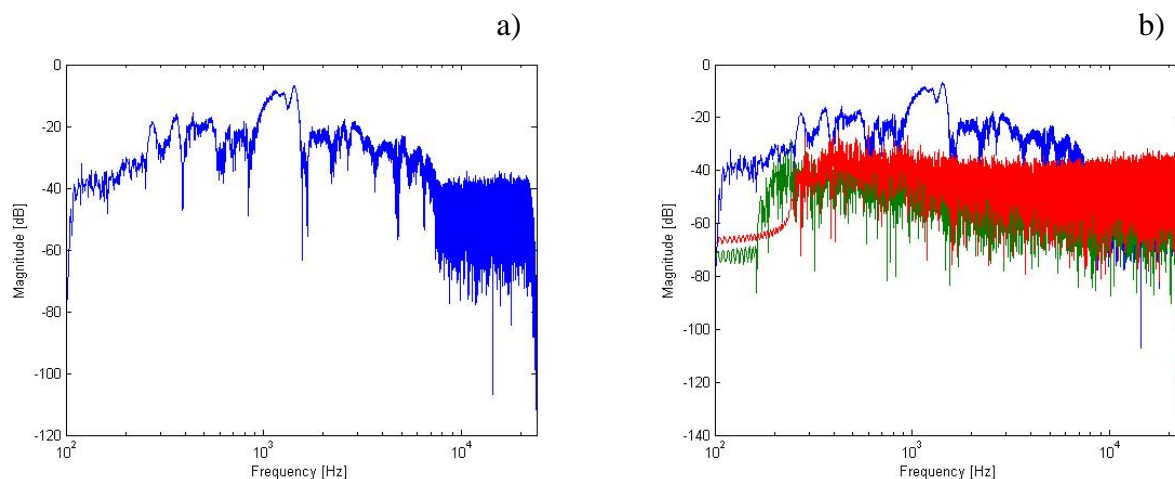

Figure 6. Signal crosstalk between left and right ear of the artificial head; a) Modulus of the signal crosstalk $H_1(f)$; b) Modulus of the signal crosstalk $H_1(f)$ together with higher non-linear components $H_n(f)$.

3.2 Measurement and Evaluation of the Transmission Chain of Audio Signals

The whole signal processing chain may include recording, signal processing, *RF* transmission and reproduction. Thus it includes a lot of components that impact the total quality of transfer and processing of the signal. Therefore, we dealt with both the individual component testing and the whole transmission chain. We continued our previous work with measurement and analysis of *FM* modulated transmission under different conditions. As an example we show the analysis of an *FM* transmission chain within the $50\text{ Hz} - 5\text{ kHz}$ frequency range. The source of the test signal was a *CD* with a 44.1 kHz sampling frequency, which enables to observe the frequency response up to the 4^{th} harmonic distorting component. Fig. 7 shows the system behavior at 0 dB and $+6\text{ dB}$ respectively.

Another application of the *SWT-MISO* method is for testing of the whole electro-acoustic chain, including digital transmission of audio signal. This system achieves significantly better parameters than analogue. The block diagram is shown on Fig. 8. The detailed analysis of the whole digital transmission system under test shows that a considerable amount of non-linear components takes place during *MPEG* compression that is used in this transmission.

Therefore we concentrated on analysis of the compression equipment performance. It is important, however, to stress that we only considered the functional performance, not the perceptual one.

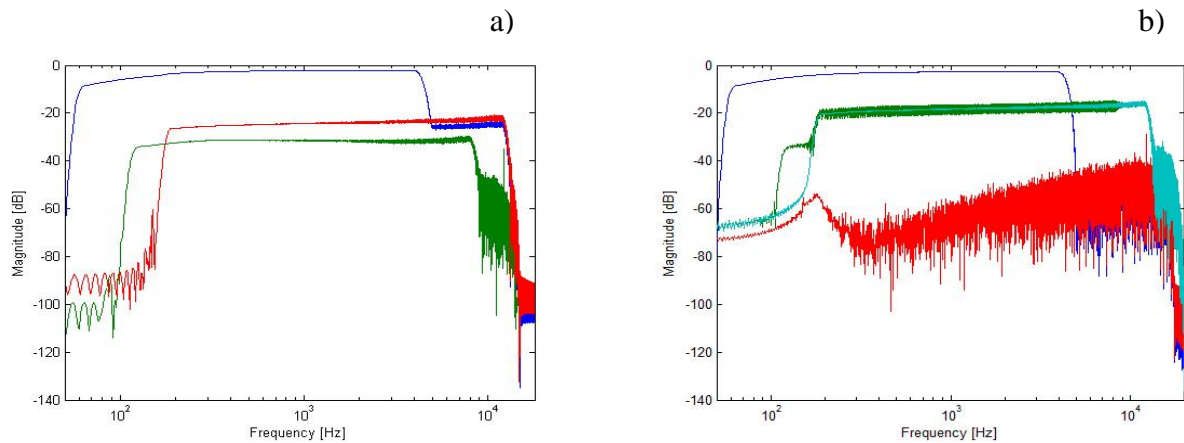

Figure 7. Modulus of the transfer function $H_I(f)$ (blue) and higher non-linear components $H_n(f)$ (other colors) of FM transmitted audio signals; a) System at 0 dB input; b) System +6 dB input.

Fig. 9 shows the result of *MPEG Pro*TM compression system performance. The graph *IR* shows the distorting components being of a low level in Fig. 9a; their spectrum is shown in Fig. 9b. The frequency response is linear within the measured range, distorting components are 60 dB or more below the level of the fundamental.

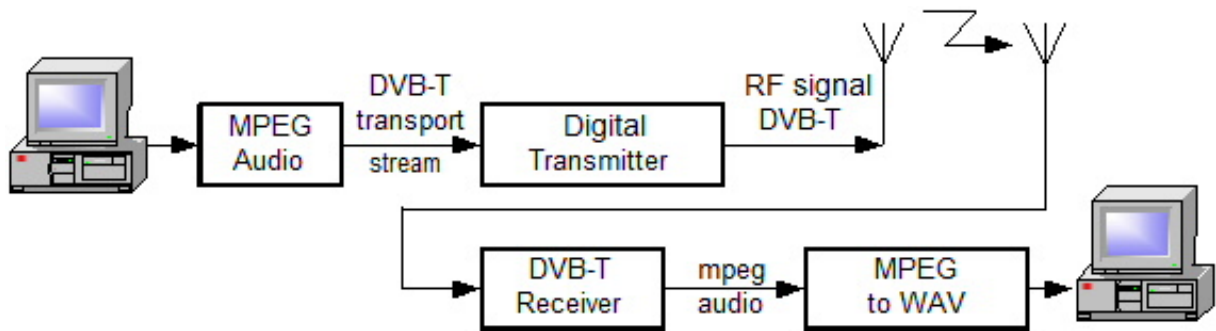

Figure 8. Block diagram of measurement and analysis of digital transmission of audio signals. a) b)

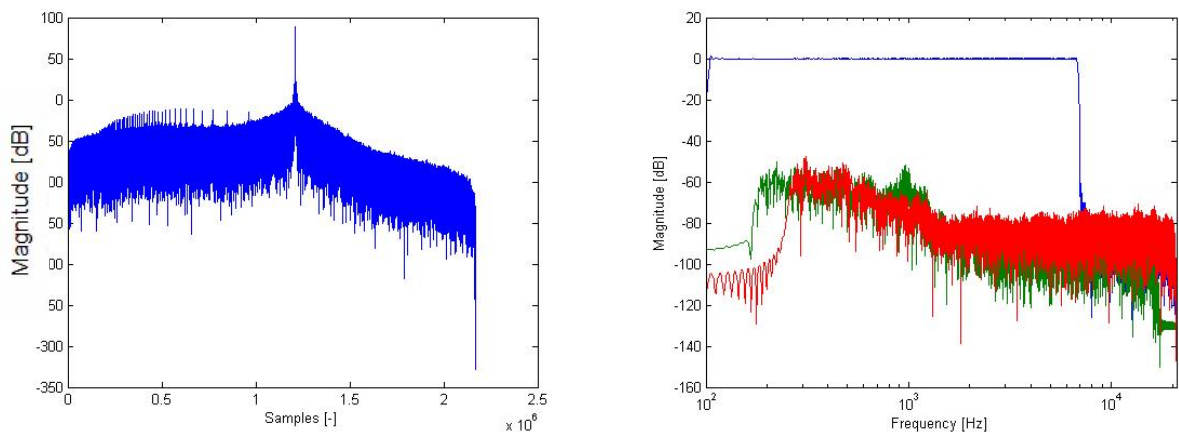

Figure 9. Analysis of swept signal $x(t)$ compressed by *MPEG Pro*TM; a) Impulse response $h_d(t)$ with sub-components $h_i(t)$; b) Modulus of transfer function $H_I(f)$ together with higher non-linear components $H_i(f)$.

4. CONCLUSIONS

In our contribution we dealt with a possibility of using a combined *SWT-MISO* method for analysis of transfer performance of an electro-acoustic system, consisting of an artificial head complete with outer ear, with headphones and measurement microphones located in ear drum positions. As well, we examined the possibility of using this analysis for modeling of sound transfer by bone conduction in human head from one ear to the other. The other application of the measuring method concerned investigation of the whole electro-acoustic chain including signal recording, *RF* transmission and its perception by the listener. We also dealt with transmission of digital audio signal. The performance of this form of transmission is significantly better than *FM* transmission. Nevertheless, we found that other low level distorting components (*MPEG* compression byproducts) limit the performance here. The combined *SWT-MISO* measuring method appears to us as a method suitable for both the detailed analysis of electro-acoustic systems with non linearities, and for actual system performance. A good correlation with traditional methods of measurement was found.

ACKNOWLEDGEMENT

This work has been supported by the Czech research project *MSM6840770014 "Research in the Area of Prospective Information and Communication Technologies"*.

REFERENCES

- [1] A. Farina, "Simultaneous Measurement of Impulse Response and Distortion with a Swept-Sine Technique", *The 108th Audio Engineering Society Convention*, Paris, February 19-22, 2000, Convention paper 5093.
- [2] A. Farina, A. Bellini, E. Armelloni, "Non-linear Convolution: a New Approach for the Auralization of Distorting Systems", *The 110th Audio Engineering Society Convention*, May 12-15, 2001, Amsterdam, Convention paper 5359.
- [3] G. Stan, J. Embrechts, D. Archambeau, "Comparision of Different Impulse Response Measurements Techniques", *Journal of Audio Engineering Society*, **50**, 2002, No. 4, pp. 249 - 262.
- [4] M. Schetzen, *The Volterra and Wiener Theories of Nonlinear Systems*, John Wiley & Sons, 1980.
- [5] Rice, H.J. &A. (1988). A generalized technique for spectral analysis of non-linear systems, Fitzpatrick, *Journal of Mechanical Systems and Signal Processing*, **2**(2), 1988, pp. 95-207.
- [6] A. Novak, L. Simon, F. Kadlec, P. Lotton, "Nonlinear System Identification Using Exponential Swept-Sine Signal," *IEEE Transactions on Instrumentation and Measurements*, To be published.